

# EATON

# Vickers

## Vane Pumps

V10, V20, V10F, V10P,  
V20F and V20P Series

### 120 inch Pad Oil Pump

V10 1P2P 1A20

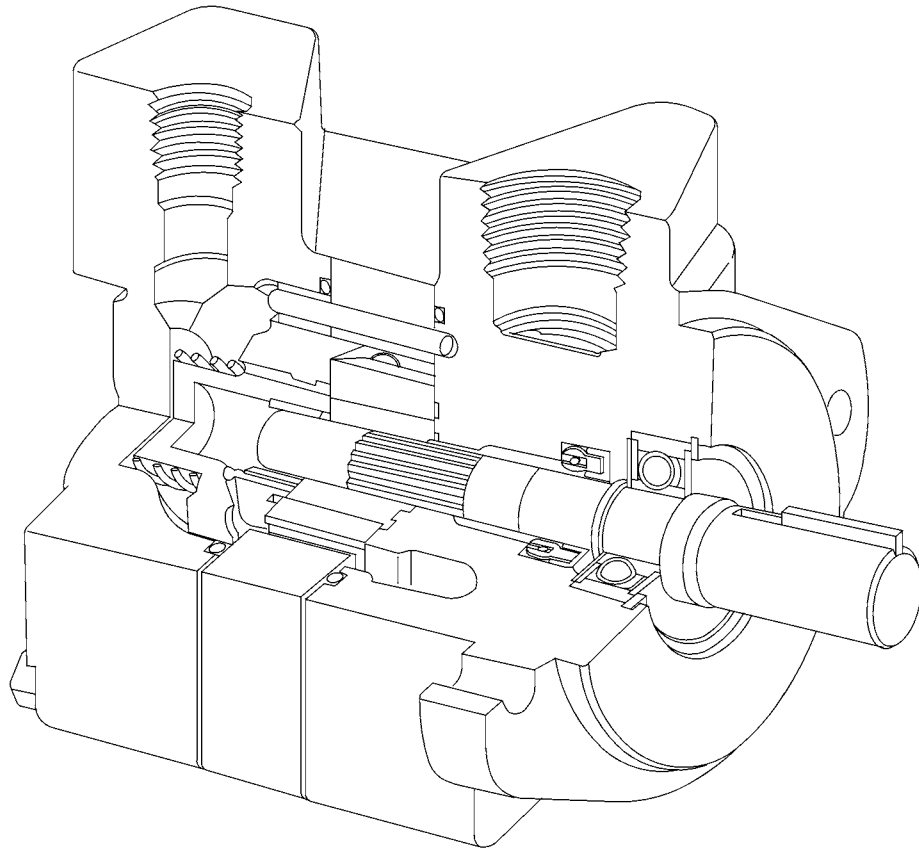

**VICKERS**<sup>®</sup>

# Table of Contents

---

Section	Page
I.	Introduction
A.	Purpose of Manual ..... 3
B.	General Information ..... 3
II.	Description
A.	General ..... 5
B.	Assembly and Construction ..... 5
C.	Flow Control and Relief Valve ..... 5
D.	Priority Valve ..... 5
E.	Application ..... 5
III.	Principles of Operation
A.	Pumping Cartridge ..... 5
B.	Hydraulic Balance ..... 6
C.	Pressure Plate ..... 6
D.	Flow Control and Relief Valve ..... 6
E.	Priority Valve Operation ..... 7
IV.	Installation and Operating Instructions
A.	Installation Drawings ..... 7
B.	Drive Connections ..... 7
C.	Shaft Rotation ..... 8
D.	Piping and Tubing ..... 8
E.	Hydraulic Fluid Recommendations ..... 8
F.	Overload Protection ..... 9
G.	Port Positions ..... 9
V.	Service, Inspection and Maintenance
A.	Service Tools ..... 9
B.	Inspection ..... 9
C.	Adding Fluid to the System ..... 9
D.	Adjustments ..... 9
E.	Lubrication ..... 10
F.	Replacement Parts ..... 10
G.	Product Life ..... 10
H.	Fluid Cleanliness ..... 10
I.	Troubleshooting ..... 10
VI.	Overhaul
A.	General ..... 12
B.	Disassembly ..... 12
C.	Inspection and Repair ..... 12
D.	Assembly ..... 14
VII.	Testing ..... 14

# Section I – Introduction

## A. Purpose of Manual

This manual has been prepared to assist the users of Vickers balanced vane type hydraulic single pumps in properly installing, maintaining and repairing their units. In the sections which follow, the single pumps are described in detail, their theory of operation is discussed and instructions are given for their proper installation, maintenance and overhaul.

The general series of models covered are V10, V20, V10F, V10P, V20F and V20P. The information given applies to the latest design configuration listed in Table 1. Earlier designs are covered only insofar as they are similar to the present equipment.

## B. General Information

**Related Publications** – Service parts information and installation dimensions are not contained in this manual. The

parts catalogs and installation drawings listed in Table 1 are available from Vickers.

**Model Codes** – There are many variations within each basic model series, which are covered by variables in the model code. Table 2 is a complete breakdown of the code covering these units. Service inquiries should always include the complete unit model number, which is stamped on the pump cover.

Model	Service Drawing	Application Catalog
V10	M-2005-S	698
V10F		353
V10P		
V20	M-2004-S	698
V20F		353
V20P		

Table 1. Service drawings and Application catalogs

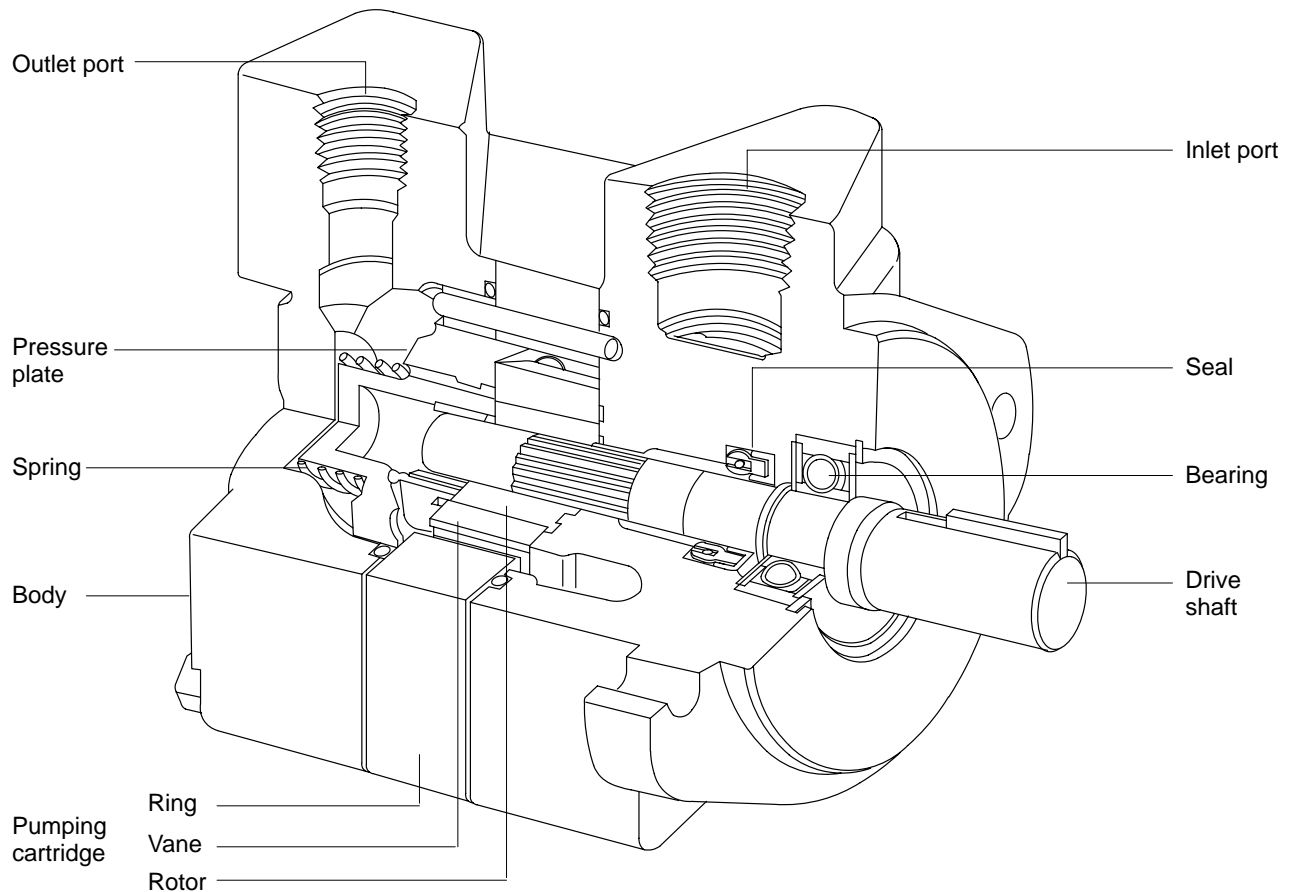
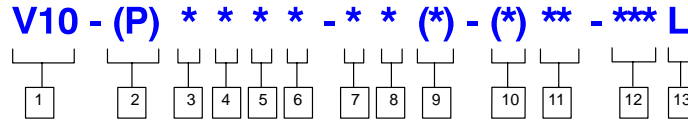

Figure 1.

# Model Code



**1 Vane pump**

10 or 20 series

**2 Integral valve options**

(Omit if not required)  
 F – Flow control & relief  
 P – Priority valve & relief

**3 Mounting**

1 – 2-bolt flange (SAE “A” size)  
 2 – Foot bracket at 12 o'clock (viewed from shaft end)  
 23 – Foot bracket at 3 o'clock  
 26 – Foot bracket at 6 o'clock  
 29 – Foot bracket at 9 o'clock

**4 Inlet port connections**

**V10 model series**

H - 1" O.D. tube connection  
 K - 1.3125"-12 UN 2B thd.  
 P - 1" NPT thd  
 S - 1.3123"-12 Straight thd.  
 T - 1.1875"-12 Straight thd.

**V20 model series**

E - 1.5" dia. – 2 bolt flange  
 F - 1.156" dia. –2 bolt flange  
 P - 1.25" NPT thd  
 R - 1" NPT thd  
 S - 1.625" –12 UN 2B thd.

**5 SAE rated capacity – USgpm**

(1200 rpm & 100 psi)

1	– 1 USgpm	} V10 series
2	– 2 USgpm	
3	– 3 USgpm	
4	– 4 USgpm	
6	– 6 USgpm	
7	– 7 USgpm	
6	– 6 USgpm	
7	– 7 USgpm	} V20 series
8	– 8 USgpm	
9	– 9 USgpm	
11	– 11 USgpm	
12	– 12 USgpm	
13	– 13 USgpm	

**6 Outlet port connections**

Code	Std. cover	Flow control cover		Priority valve cover		
		Pressure	Tank	Primary outlet	Secondary outlet	Tank
K	–	–	–	9/16-18 St. thd. (V10P)	3/4-16 St. thd. (V10P)	9/16-18 St. thd. (V10P)
P	.50" NPT thd. (V10)	–	–	–	–	–
	.75" NPT thd. (V20)	3/4-16 St. thd. (V10F & V20F)	1/2" NPT thd. (V10F & V20F)	–	–	–
R	1.062–12 St. thd. (V10)	–	–	–	–	–
S	.750"–16 St. thd. (V10)	–	–	–	–	–
	1.062–12 St. thd. (V20)	3/4-16 St. thd. (V20F)	1-1/16–12 St. thd. (V20F)	–	–	–
T	–	3/4-16 St. thd. (V10F)	3/4-16 St. thd. (V10F)	3/4-16 St. thd. (V20P)	7/8-14 St. thd. (V20P)	3/4-16 St. thd. (V20P)
Y	.875–14 St. thd	–	–	–	–	–

**7 Shafts**

1 – Straight keyed  
 3 – Threaded with woodruff key  
 4 – Threaded  
 11 – Splined 9 teeth  
 12 – Splined 13 teeth (V10 only)  
 15 – Splined 13 teeth  
 27 – Tang  
 34 – Threaded  
 38 – Splined 11 teeth  
 62 – SAE A Spline (V20 only)

**8 Position of outlet or primary outlet port**

(Viewed from cover end of pump)

A – Opposite inlet port  
 B – 90° CCW from inlet  
 C – In line with inlet  
 D – 90° CW from inlet

**9 Flow rate through orifice in cover**

1 – 1 USgpm (V10P)  
 2 – 2 USgpm (V10F)  
 8 – 8 USgpm (V20F)

**10 Pressure setting**

A – 250 psi  
 B – 500 psi  
 C – 750 psi  
 D – 1000 psi  
 E – 1250 psi  
 F – 1500 psi  
 G – 1750 psi  
 H – 2000 psi  
 J – 2250 psi  
 K – 2500 psi

**11 Design**

Subject to change. Installation dimensions remain the same for designs –20 through –29.

**12 Special feature suffix**

**13 Shaft rotation**

(Viewed from shaft end of pump)  
 L – Left hand for counterclockwise.  
 Omit for right hand.

## Section II – Description

### A. General

Pumps in this series are used to develop hydraulic fluid flow for the operation of Mobile and Industrial equipment. The positive displacement pumping cartridges are the rotary vane type with shaft side loads hydraulically balanced. The flow rate depends on the pump size and the speed at which it is driven.

All units are designed so that the direction of rotation, pumping capacity and port positions can be readily changed to suit particular applications.

### B. Assembly and Construction

The V10 series pump illustrated in the cut away of Figure 1 is representative of all single pumps in this series. The unit consists principally of a ported body, a ported cover and a pumping cartridge. Components of the pumping cartridge are an elliptical cam ring, a slotted rotor splined to fit the drive shaft and twelve vanes fitted to the rotor slots.

The pumping cartridge cam ring is sandwiched between the body and cover. A ball bearing and bushing located in the body and pressure plate respectively support each end of the drive shaft and center the rotor within the cam ring. As the drive shaft is driven by the prime mover, the rotor and vanes generate flow by carrying fluid around the elliptical cam ring contour. Fluid enters the cartridge through the inlet

port in the body and is discharged through the pressure plate into the outlet port of the cover.

### C. Flow Control and Relief Valve

V10 and V20 pumps are available with an integral flow control and relief valve in the pump cover. This limits the final flow in the system to a maximum prescribed rate and prevents excessive pressure buildup. Fluid not required in the system is recirculated to tank.

### D. Priority Valve

V10 and V20 pumps are also available with a priority valve located in the pump cover. The priority valve maintains nearly a constant flow to a primary circuit and diverts the remaining flow to a secondary circuit. Flow going to the secondary circuit is determined by pump delivery. The primary circuit is protected by an integral relief valve, but an external relief valve must be provided for the secondary circuit.

### E. Application

Pump ratings in USgpm, as shown in the model coding are at 1200 rpm and 100 psi. For ratings at other speeds, methods of installation and other application information Vickers Engineering personnel should be consulted.

## Section III – Principles of Operation

### A. Pumping Cartridge

As mentioned in Section II, fluid flow is developed by the pumping cartridge. The action of the cartridge is illustrated in Figure 2. The rotor is driven within the cam ring by the driveshaft, which is coupled to a power source. As the rotor turns, centrifugal force causes the vanes to follow the elliptical inner surface of the cam ring.

Radial movement of the vanes and turning of the rotor causes the chamber volume between the vanes to increase

as the vanes pass the inlet sections of the cam ring. This results in a low pressure condition which allows atmospheric pressure to force fluid into the chambers. (Fluid outside the inlet is at atmospheric pressure or higher.)

This fluid is trapped between the vanes and carried past the large diameter or dwell section of the cam ring. As the outlet section is approached, the cam ring diameter decreases and the fluid is forced out into the system. System pressure is fed under the vanes, assuring their sealing contact against the cam ring during normal operation.

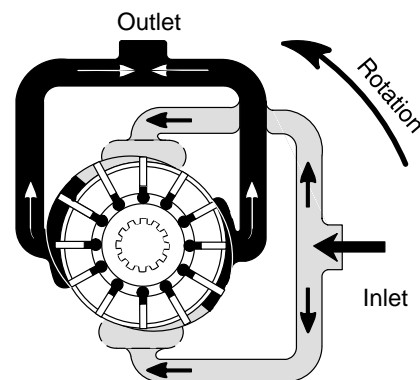
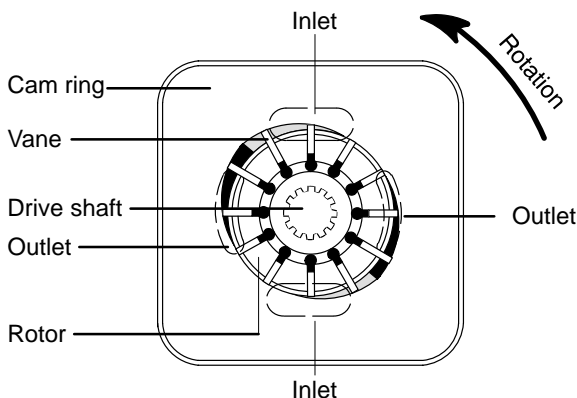

Figure 2.

## B. Hydraulic Balance

The pump cam ring is shaped so that the two pumping chambers are formed diametrically opposed. Thus, hydraulic forces which would impose side loads on the shaft are cancelled.

## C. Pressure Plate

The pressure plate seals the pumping chamber as shown in Figure 3. A light spring holds the plate against the cartridge until pressure builds up in the system. System pressure is effective against the area at the back of the plate, which is larger than the area exposed to the pumping cartridge. Thus, an unbalanced force holds the plate against the cartridge, sealing the cartridge and providing the proper running clearance for the rotor and vanes.

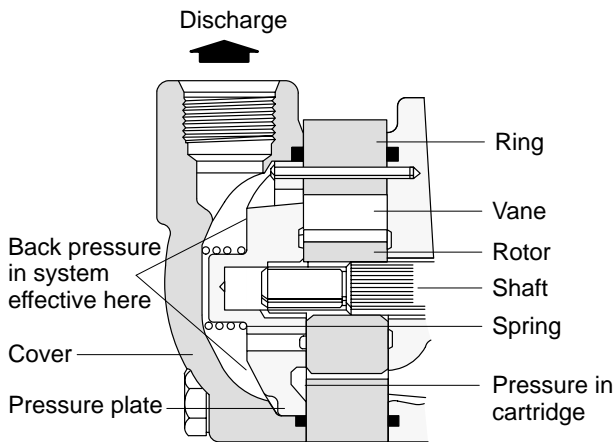

Figure 3.

## D. Flow Control and Relief Valve

1. Maximum flow to the operating circuit and maximum system pressure are determined by the integral flow control and relief valve in a special outlet cover used on some V10 and V20 pumps. This feature is illustrated pictorially in Figure 4. An orifice in the cover limits maximum flow. A pilot operated type relief valve shifts to divert excess fluid delivery to tank, thus limiting the system pressure to a predetermined maximum.
2. Figure 4A shows the condition when the total pump delivery can be passed through the orifice. This condition usually occurs only at low drive speeds. The large spring chamber is connected to the pressure port through an orifice. Pressure plus spring load in this chamber slightly exceeds pressure at the other end of the relief valve spool and the spool remains closed. Pump delivery is blocked from the tank port by the spool land.
3. When pump delivery is more than the flow rate determined by the orifice plug, pressure builds up across the orifice and forces the spool open against the light spring. Excess fluid is throttled past the spool to the tank port as shown in Figure 4B.
4. If pressure in the system builds up to the relief valve setting (Figure 4C), the pilot poppet is forced off its seat. Fluid in the large spring chamber flows through the spool and out to tank. This flow through the small sensing orifice, causes a pressure drop and prevents pressure in the large spring area from increasing beyond the relief valve setting. As pressure against the right end of the spool starts to exceed the relief valve setting, the pressure differential forces the spool to the left, against the light spring, porting the full pump flow to tank.

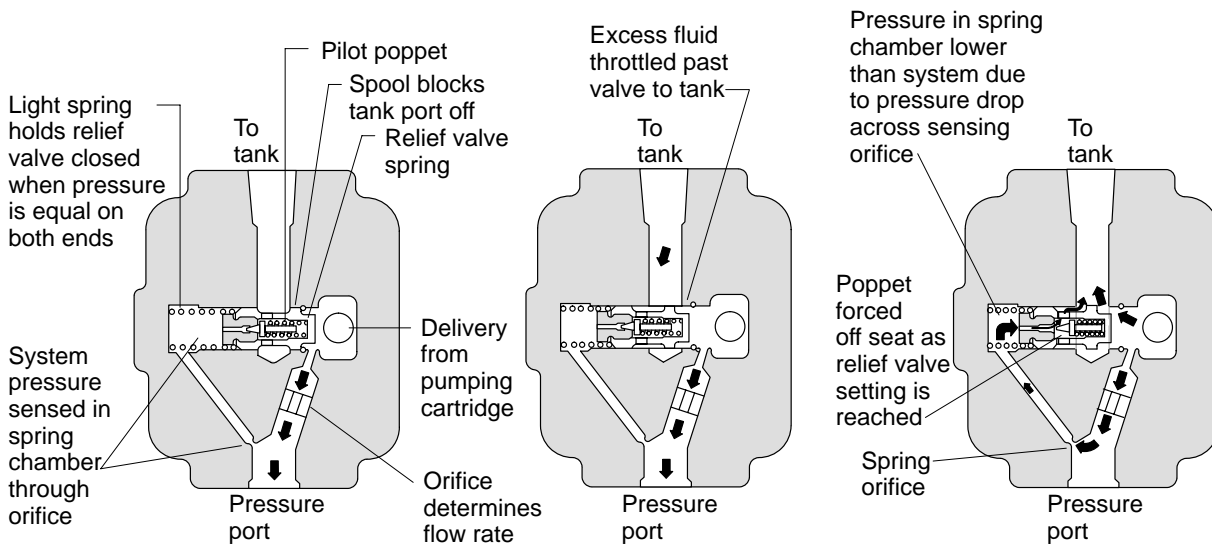

Figure 4A  
Low Drive Speed – All Pump  
Delivery to System

Figure 4B  
Normal Operation

Figure 4C  
Excessive Pressure  
Build-Up in System

## E. Priority Valve Operation

Referring to the V20P cover schematic, Figure 5, pressure is sensed in cavities "A", "B" and "C". Primary flow into cavity "A" is restricted by the controlled flow orifice "O". Secondary flow will be zero until the pump flow rate through orifice "O" develops a pressure differential across the control spool.

When pump delivery is increased, pressure builds up in cavities "B" and "C" because of the resistance to flow through orifice "O". This causes the spool to shift toward cavity "A" against the spring. The amount of spool shift is proportional to the pressure differential between cavities "A" and "C".

Flow from the primary port is held to an almost constant volume, as determined by orifice "O" and the metering action of the control spool at area "D". Flow to the secondary port varies with pump delivery. Metering area "E" diverts excess flow to the secondary port.

This single spool design cannot give precisely controlled flow to the primary circuit because of the effects of varying conditions of flows and pressures. For example: If the primary circuit is operating at 1000 psi and the secondary at 100 psi, the spool must be metering at "E". However, if primary pressure is 100 psi and secondary is 1000 psi, the spool must be metering at "D". As the two systems approach the same pressure, the probability of flow fluctuation increases because the spool may shift between these two metering points.

### CAUTION

The pump has a built-in relief valve in the primary circuit. However, an external relief valve must be provided for the secondary circuit to protect the pump.

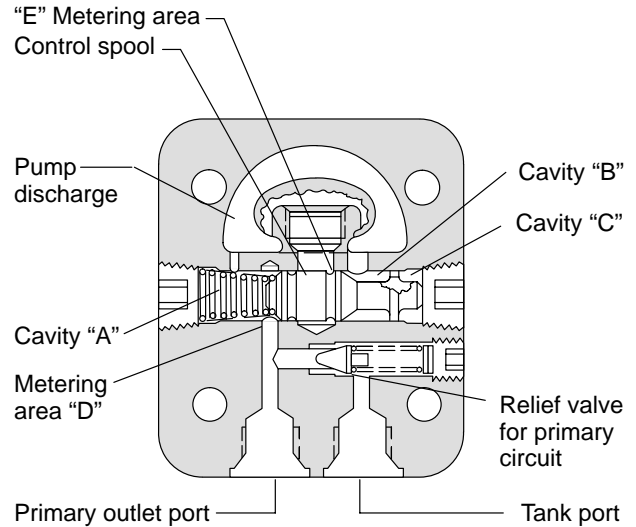

Figure 5.

## Section IV – Installation and Operating Instructions

### A. Installation Drawings

The application catalogs listed in Table 1 show the correct installation dimensions and port locations.

### B. Drive Connections



### CAUTION

*Pump shafts are designed to be installed in couplings, pulley, etc., with a slip fit or very tight tap. Pounding can injure the bearings. Shaft tolerances are shown on pump installation drawings. (See Table 1.)*

1. Direct Mounting – A pilot on the pump mounting flange (Figure 6) assures correct mounting and shaft alignment. Make sure the pilot is firmly seated in the accessory pad of the power source. Care should be exercised in tightening the mounting screws to prevent

misalignment.. If gaskets are used, they should be installed carefully and should lay flat. Shaft keys and couplings must be properly seated to avoid slipping and possible shearing.

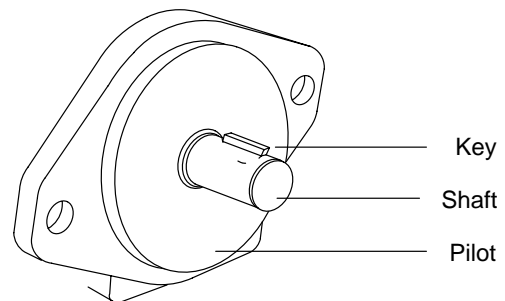

Figure 6.

2. Indirect Drive – Chain, spur gear or v-belt pulley drives may also be used with these pumps. Flat belt drives are not recommended because of the possibility of slipping.

To prevent excessive side loads on pump bearings, it is important to check for correct alignment and guard against excessive belt or chain tension.

For best results on indirect drive applications, use the largest permissible pulley diameter at the pump and position it as close as possible to the pump mounting face. For specific indirect drive application data, contact your Vickers representative.

## C. Shaft Rotation

Pumps are normally assembled for right-hand (clockwise) rotation as viewed from the shaft end. A pump made for left-hand rotation is identified by an “L” in the model code

### NOTE

These pumps must be driven in the direction of the arrows cast on the pump ring. If it is desired to change the direction of drive rotation, it is necessary to reverse the ring. (See Section 6, B–D and Figure 10.)



### CAUTION

*Never drive a pump in the wrong direction of rotation. Seizure may result, necessitating expensive repairs.*

## D. Piping and Tubing

1. All pipes and tubing must be thoroughly cleaned before installation. Recommended methods of cleaning are sand blasting, wire brushing and pickling.

### NOTE

For instructions on pickling refer to catalog 674.

2. To minimize flow resistance and the possibility of leakage, only as many fittings and connections as are necessary for proper installation should be used.
3. The number of bends in tubing should be kept to a minimum to prevent excessive turbulence and friction of oil flow. Tubing must not be bent too sharply. Recommended radius for bends is three times the inside diameter of the tube.

## E. Hydraulic Fluid Recommendations

### General Data

Oil in a hydraulic system performs the dual function of lubrication and transmission of power. It constitutes a vital factor in a hydraulic system, and careful selection of it should be made with the assistance of a reputable supplier. Proper selection of oil assures satisfactory life and operation of system components with particular emphasis on hydraulic pumps. Any oil selected for use with pumps is acceptable for use with valves or motors.

### NOTE

For oil recommendations refer to catalog 674.

Where special considerations indicate a need to depart from the recommended oils or operating conditions, see your Vickers representative.

### Cleanliness

Thorough precautions should always be observed to insure the hydraulic system is clean:

1. Clean (flush) entire new system to remove paint, metal chips, welding shot, etc.
2. Filter each change of oil to prevent introduction of contaminants into the system.
3. Provide continuous oil filtration to remove sludge and products of wear and corrosion generated during the life of the system.
4. Provide continuous protection of system from entry of airborne contamination by sealing the system and/or by proper filtration of the air.
5. During usage, proper oil filling and servicing of filter, breathers, reservoirs, etc., cannot be over emphasized.
6. Thorough precautions should be taken by proper system and reservoir design, to insure that aeration of the oil will be kept to a minimum.

Vickers supports and recommends the hydraulic Systems Standards for Stationary Industrial Machinery advanced by the American National Standards Institute; ANSI/(NFPA/JIC) T2.24.1–1991. Key elements of this Standard as well as other vital information on the correct methods for treating hydraulic fluid are included in Vickers publication #561; “Vickers Guide to Systemic Contamination Control,” available from your local Vickers distributor or by contacting Vickers, Incorporated. Recommendations on filtration and the selection of products to control fluid condition are included in this publication.



## F. Overload Protection

A relief valve must be installed in the system, unless it is an integral part of the pump. The relief valve limits pressure in the system to a prescribed maximum and protects the component from excessive pressure. The setting of the relief valve depends on the work requirements of the system components.

## G. Port Positions

The pump cover can be assembled in four positions with respect to the body. A letter in the model code (Table 2) identifies the cover position as shown in Figure 7.

Disassembly and assembly procedures are in Section 6 B and D.

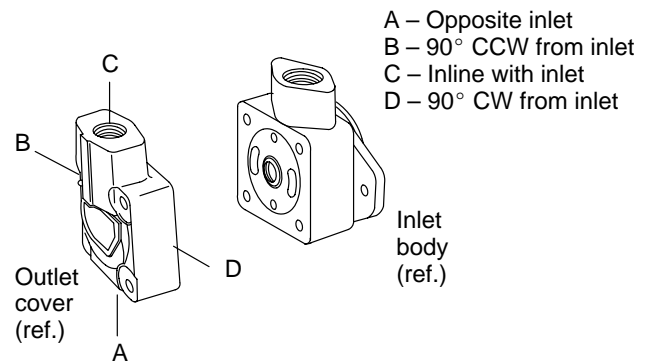

Figure 7.

## H. Start-Up

With a minimum drive speed of 600 rpm, a pump should prime almost immediately, if provision is made to initially purge the air from the system. Failure to prime within a reasonable length of time may result in damage due to lack of lubrication. Inlet lines must be tight and free from air leaks. However, it may be necessary to crack a fitting on the outlet side of the pump to purge entrapped air.

# Section V – Service, Inspection and Maintenance

## A. Service Tools

No special tools are required to service these pumps.

## B. Inspection

Periodic inspection of the fluid condition and tube or piping connections can save time-consuming breakdowns and unnecessary parts replacement. The following should be checked regularly.

1. All hydraulic connections must be kept tight. A loose connection in a pressure line will permit the fluid to leak out. If the fluid level becomes so low as to uncover the inlet pipe opening in the reservoir, extensive damage to the pump can result. In suction or return lines, loose connections permit air to be drawn into the system resulting in noisy and/or erratic operation.
2. Clean fluid is the best insurance for long service life. Therefore, the reservoir should be checked periodically for dirt or other contaminants. If the fluid becomes contaminated, the system should be drained and the reservoir cleaned before new fluid is added.
3. Filter elements also should be checked and replaced periodically. A clogged filter element results in a higher pressure drop. This can force particles through the filter which would ordinarily be trapped, or can cause the

by-pass to open, resulting in a partial or complete loss of filtration.

4. Air bubbles in the reservoir can ruin the pump and other components. If bubbles are seen, locate the source of the air and seal the leak.
5. A pump which is running excessively hot or noisy is a potential failure. Should a pump become noisy or overheated, the machine should be shut down immediately and the cause of improper operation corrected.

## C. Adding Fluid to the System

When hydraulic fluid is added to the system, it should be pumped through a 10 micron absolute filter. The use of a Clean-Cart unit to filter clean fluid into the system is recommended. For further information on the Clean-Cart unit, obtain catalog 601.

It is important that the fluid be kept clean and free from any substance that may cause improper operation or wear to the pump and other hydraulic units. Therefore, the use of cloth to strain the fluid should be avoided to prevent lint from entering the system.

## D. Adjustments

No periodic adjustments are required other than to maintain proper shaft alignment with the driving medium.

---

## Sound Level

Noise is only indirectly affected by the fluid selection, but the condition of the fluid is of paramount importance in obtaining optimum reduction of system sound levels.

Some of the major factors affecting the fluid conditions that cause the loudest noises in a hydraulic system are:

1. Very high viscosities at start-up temperature can cause pump noises due to cavitation.
2. Running with a moderately high viscosity fluid will slow the release of air captured in the fluid. The fluid will not be completely purged of such air in the time it remains in the reservoir before recycling through the system.
3. Aerated fluid can be caused by ingestion of air through the pipe joints of inlet lines, high velocity discharge lines, cylinder rod packings or by fluid discharging above the fluid level in the reservoir. Air in the fluid causes a noise similar to cavitation.
4. Contaminated fluids can cause excessive wear of internal pump parts which may result in increased sound levels.

## E. Lubrication

Internal lubrication is provided by the fluid in the system. Lubrication of the shaft couplings should be as specified by their manufacturers.

## F. Replacement Parts

Reliable operation throughout the specified operating range is assured only if genuine parts are used. Sophisticated design process and material are used in the manufacture of our parts. Substitutes may result in early failure. Part numbers are shown in the service parts drawings listed on page 3.

## G. Product Life

The service life of these products is dependent upon environment, duty cycle, operating parameters and system cleanliness. Since these parameters vary from application to application, the ultimate user must determine and establish the periodic maintenance required to maximize life and detect component failure.

## H. Fluid Cleanliness

Proper fluid condition is essential for long and satisfactory life of hydraulic components and systems. Hydraulic fluid must have the correct balance of cleanliness, materials and additives for protection against wear of components, elevated viscosity and inclusion of air.

Essential information on the correct methods for treating hydraulic fluid is included in Vickers publication 561; "Vickers Guide to Systemic Contamination control," available from your local Vickers distributor or by contacting Vickers, Incorporated.

Recommendation of filtration and the selection of products to control fluid condition are included in 561.

Recommended cleanliness levels using petroleum oil under common conditions is based on the highest fluid pressure levels in the system.

Piston pumps, regardless of manufacturer, will operate with fluids showing a higher cleanliness code. The operating life of the pump, and other components in the system, will be less however. For maximum life and best system performance, cleanliness codes as defined below should be achieved.

Fluids other than petroleum, severe service cycles or temperature extremes are cause for adjustment of these cleanliness codes. See Vickers Publication 561 for exact details.

---

### System Pressure Level

Product	1000psi	2000 psi	3000+ psi
Vane pumps, fixed	20/18/15	19/17/14	18/16/13
Vane pumps, variable	18/16/14	17/15/13	
Piston pumps, fixed	19/17/15	18/16/14	17/15/13
Piston pumps, variable	18/16/14	17/15/13	16/14/12
Directional valves		20/18/15	19/17/14
Proportional valves		17/15/12	15/13/11
Pressure/Flow controls		19/17/14	19/17/14
Cylinders	20/18/15	20/18/15	20/18/15
Vane motors	20/18/15	19/17/14	18/16/13
Axial piston motors	19/17/14	18/16/13	17/15/12
Radial piston motors	20/18/14	19/17/13	18/16/13

## I. Troubleshooting

Table 6 lists the common difficulties experienced with vane pumps and hydraulic systems. It also indicates the probable causes and remedies for each of the troubles listed.

It should always be remembered that many apparent pump failures are actually the failures of other parts of the system. The cause of improper operation is best diagnosed with adequate testing equipment and a thorough understanding of the complete hydraulic system.

# Troubleshooting

TROUBLE	PROBABLE CAUSE	REMEDY
Pump not delivering fluid	Driven in the wrong direction of rotation	The drive direction must be changed immediately to prevent seizure. Figure 10 shows the correct ring position for each direction of rotation.
	Coupling or shaft sheared or disengaged.	Disassemble the pump and check the shaft and cartridge for damage. (See Section VI.) Replace the necessary parts.
	Fluid intake pipe in reservoir restricted	Check all strainers and filters for dirt and sludge. Clean if necessary.
	Fluid viscosity too heavy to pick up prime.	Completely drain the system. Add new filtered fluid of the proper viscosity.
	Air leaks at the intake. Pump not priming	Check the inlet connections to determine where air is being drawn in. Tighten any loose connections. See that the fluid in the reservoir is above the intake pipe opening. Check the minimum drive speed which may be too slow to prime the pump.
	Relief valve stuck open. (Models with integral relief valve only)	Disassemble the pump and wash the valve in clean solvent. Return the valve to its bore and check for any stickiness. A gritty feeling on the valve periphery can be polished with crocus cloth. Do not remove excess material, round off the edges of the lands or attempt to polish the bore. Wash all parts and reassemble the pump.
Insufficient pressure build-up	Vane(s) stuck in the rotor slot(s)	Disassemble the pump. Check for dirt or metal chips. Clean the part thoroughly and replace any damaged pieces. If necessary, flush the system and refill it with clean fluid.
	System relief valve set too low	Use a pressure gage to correctly adjust the relief valve.
Pump making noise	Complete loss of flow from pump.	<ul style="list-style-type: none"> <li>– A valve is stuck open permitting free flow to tank.</li> <li>– Broken inlet or pressure line.</li> <li>– Actuator bypassing the full flow. (Motor valve plate lift)</li> </ul>
	Pump intake partially blocked	Service the intake strainers. Check the fluid condition and, if necessary, drain and flush the system. Refill with clean fluid.
	Air leaks at the intake or shaft seal. (Oil in reservoir would probably be foamy)	Check the inlet connections and seal to determine where air is being drawn in. Tighten any loose connections and replace the seal if necessary. See that the fluid in the reservoir is above the intake pipe opening.
	Pump drive speed too slow or too fast	Operate the pump at the recommended speed
	Coupling misalignment	Check if the shaft seal bearing or other parts have been damaged. Replace any damaged parts. Realign the coupled shafts.

Figure 6. Trouble Shooting Chart

# Section VI – Overhaul



## WARNING

*Before breaking the circuit connection, make sure power is OFF and system pressure is released. Lower all vertical cylinders, discharge accumulators, and block any load that could generate pressure.*

## A. General

Plug all removed units and cap all lines to prevent the entry of dirt into the system. During disassembly, pay particular attention to identification of the parts, especially the cartridges, for correct assembly.

Pump bearings are pressed in the bodies or on the shafts and should not be removed unless defective. Figure 8 is an exploded view which shows the proper relationship of the parts for disassembly and assembly. Refer to Figure 1 and Figure 8 for the correct assembled relationship of the parts.

## B. Disassembly

1. Disassembly of Basic Pump – See Figure 8. If a foot bracket is used, remove before dismantling the pump. Clamp the pump body in a vise (not too tightly), cover end up, and remove the four cover screws. Note the position of the cover port with respect to the body port before lifting off the cover and “O” ring. (See paragraph 2 for disassembly of flow control covers and paragraph 3 for disassembly of the priority valve covers).

Remove the pressure plate and spring. Note the position of the ring for correct reassembly. Lift off the ring and remove the locating pins. Separate the vanes from the rotor and remove the rotor from the shaft.

Turn the pump body over, then remove the shaft key and the snap ring which retains the bearing. Tap with a soft hammer on the splined end of the shaft to force the shaft out of the body. Remove the small snap ring, located on the shaft, behind the bearing. Support the bearing inner race and press the shaft out of the bearing. Pull the shaft seal out of the body with a suitable hooked tool.



## CAUTION

*Do not disassemble the relief valve S/A removed in the following step. The unit is factory set and could malfunction if disassembled.*

2. Disassembly of Flow Control and Relief Valve Covers – See Figure 8. Remove the plug and “O” ring from the snap ring side of the cover. Then remove the plug and “O” ring that releases the spring and relief valve S/A. Insert a suitable tool from the snap ring end of the bore.

Slide the relief valve S/A from the cover. Remove the snap ring with care DO NOT scratch the bore.

3. Disassembly of the Priority Valve Cover – See Figure 8. Remove the plug, “O” ring and spring from one end of the priority valve bore, and the plug and “O” ring from the other end of the bore. Insert a suitable tool into the snap ring end of the bore (Snap ring used with pipe thread plugs only) and slide the priority valve spool from the cover. If the snap ring exists, remove it from the cover. Disassemble the relief valve by removing the plug, spring, poppet and shims. On later designs a spring guide is used. See Figure 8. DO NOT remove the seat unless inspection of the poppet contact area reveals a problem in the seat area. If removal of the seat is required, thread the seat with a suitable tap approximately 3/8 inch into the seat. Thread a long bolt into the seat and pull the bolt and seat from the bore with a small gear puller.

## C. Inspection and Repair

### Cleaning

All parts must be thoroughly cleaned and kept clean during inspection and assembly. The close tolerance of the parts makes this requirement more stringent than usual. Clean all removed parts using a commercial solvent that is compatible with the system fluid. Compressed air may be used in cleaning, but it must be filtered to remove water and contamination. Clean compressed air is particularly useful in cleaning spools, orifices and cover passages.

1. Discard the used shaft seal and all “O” rings. Wash the metal parts in a solvent, blow them dry with filtered compressed air and place them on a clean surface for inspection.
2. Check the wearing surfaces of the body, pressure plate, ring and rotor for scoring and excessive wear. Remove light score marks by lapping. Replace any heavily scored or badly worn parts.
3. Inspect the vanes for burrs, wear and excessive play in the rotor slots. Replace the vanes and rotor if the slots are worn.
4. Check the bearings for wear and looseness. Rotate the bearings while applying pressure to check for pitted or cracked races.
5. Inspect the oil seal mating surface on the shaft for scoring or wear. If marks on the shaft cannot be removed by light polishing, replace the shaft.
6. Flow Control Cover – Check the relief valve sub-assembly for free movement in the cover bore. Remove burrs from the valve by polishing, but DO NOT round off the corners of the lands. DO NOT attempt to rework the valve bore. If the bore is damaged, replace the cover.

NOTE

**Priority Cover Information**

V10-10 early models and V20-11 design models use pipe threaded plugs.

V10-10 current design and V20-12 models use straight threaded plugs and "O" rings.

**Flow Control Cover Information**

V10-20 early models and V20-11 design models use pipe threaded plugs.

V10-20 current design models use straight threaded plugs and "O" rings. The V20-11 is the current design and uses pipe threaded plugs.

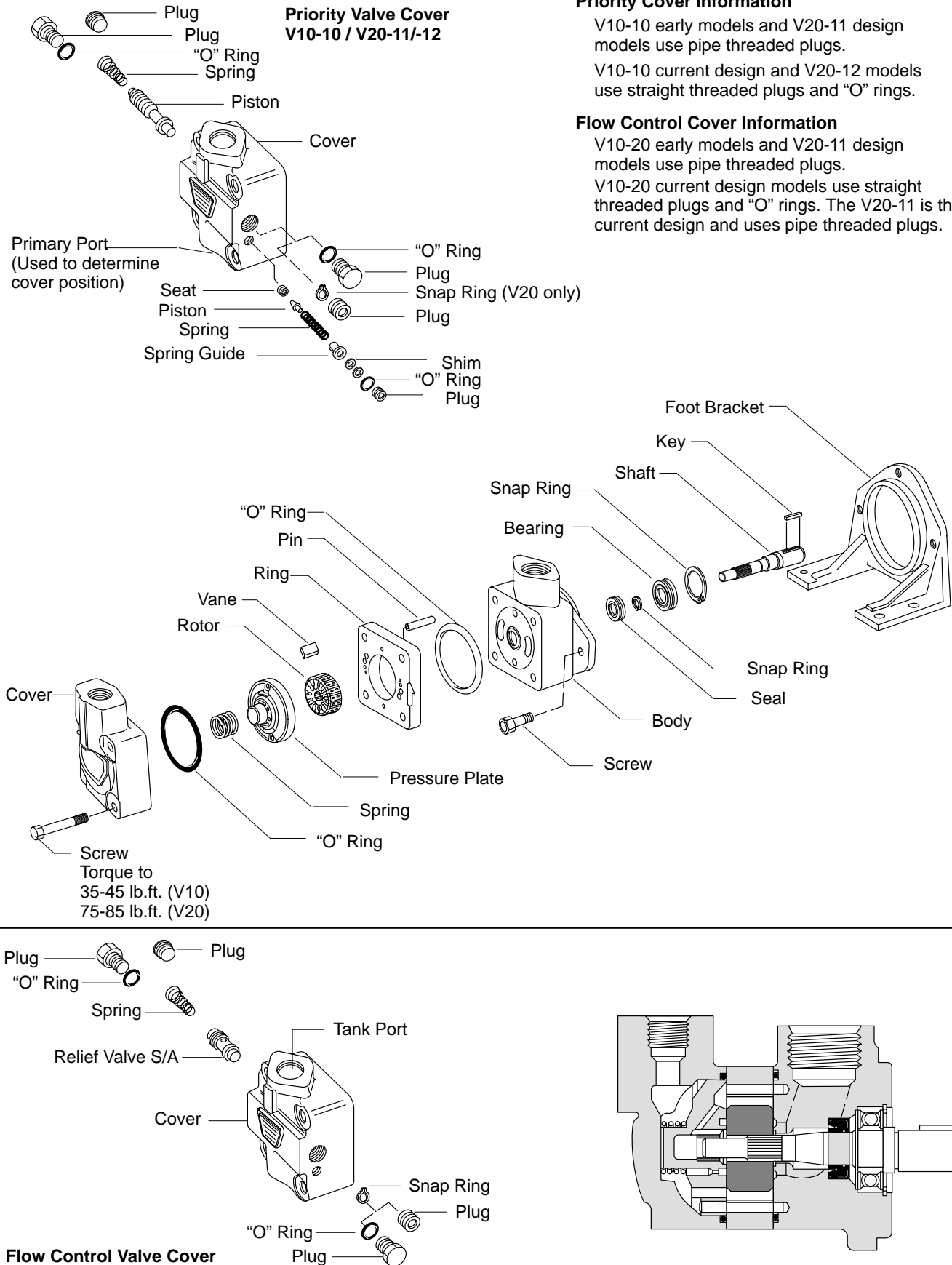

Figure 8.

- Priority Valve Cover – Inspect the priority valve spool and bore for burrs. Remove burrs from the spool by light polishing with crocus or #500 grit paper. DO NOT round off sharp corners of the lands. Inspect the cover bore for scratches, wear and/or a pitted surface. DO NOT attempt to rework the bore. If the bore is damaged, replace the cover. The priority valve spool must fit and move within the bore without evidence of bind. Rotate the spool through 360° while inspecting for bind. Inspect the snap ring for damage. (V20 units only). If worn or bent, replace with a new snap ring. If the snap ring is bent, inspect the snap ring groove in the cover for sufficient depth and rounded edges of the snap ring groove. If the groove is defective, replace the cover.

Integral Relief Valve – Inspect the spring. The spring ends must be parallel to prevent cocking of the poppet. The poppet requires a close inspection in the seat contact area. A slight wear pattern should exist around the poppet area of seat contact. If the wear pattern is broken, a possible leakage path exists between the poppet and seat. Inspect the seat for possible erosion or other defects. Refer to the seat removal procedure if the seat is defective.

## D. Assembly

Coat all parts with hydraulic fluid to facilitate assembly and provide initial lubrication. Use small amounts of petroleum jelly to hold “O” rings in place during assembly.

### IMPORTANT

During handling and shipping of the precision machined cartridge parts, it is possible to raise burrs on the sharp edges. All sharp edges on the parts of a new cartridge kit should be stoned, prior to installation.

- Assembly of Flow Control Cover – See Figure 8. Assemble the snap ring in place within the bore, (early design only) seat firmly in the groove. Insert the valve in the bore, smallest land first. Then install the spring and both plugs. Use new “O” rings if straight thread plugs are used.
- Assembly of Priority Valve Cover – See Figure 8. If the relief valve seat was removed, a new seat must be pressed into the body. Lubricate and insert the new seat chamfered end first into the cover opening. Align square and press into place. Use a short length of brass rod as a pressing tool, to prevent seat damage. Clean the relief valve bore to remove chips and filings. Insert the poppet into the bore, align square and lightly tap the stem of the poppet to mate the poppet and seat. Install the spring, shims and plug into the cover. (Later designs use a spring guide and straight thread plug with “O” rings). Be sure to check the pressure setting of the relief valve against the model code. If the setting is out of tolerance, readjust by removing or adding shims. (Removing shims reduces pressure while adding shims increases pressure.)

Priority Valve – Install the snap ring within the priority valve cover bore (earlier V20 series only); make sure the snap ring is seated within its groove. Insert the

priority valve spool, small land first, into the bore. Install plugs at each end of the bore and secure. Refer to Figure 8 for spool orientation.

- Assembly of Pump – See Figure 8. Begin assembly by pressing the shaft into the front bearing while supporting the bearing inner race. Install the small snap ring on the shaft.

### NOTE

Before assembling the shaft seal, determine the correct position of the sealing lip. (See Figure 9.) Seals are assembled with the garter spring toward the pumping cartridge. Press the seal firmly in place and lubricate the lip with petroleum jelly or other grease compatible with the system fluid. Slide the drive shaft into the body until the bearing is seated. Tap lightly on the end of the shaft if necessary. Install the snap ring.

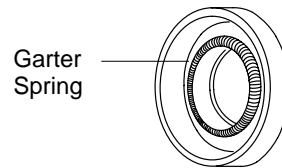

Shaft Seal

Assemble with spring toward cover end of pump

Figure 9.

Install new “O” rings in the body and cover. Insert the ring locating pins in the body and assemble the ring so that the arrow on the perimeter points in the direction of rotation. Check the assembly against Figure 10. Install the rotor on the shaft and insert the vanes in the rotor slots. Be certain the radius edges of the vanes are toward the cam ring.

Place the pressure plate on the locating pins and flat against the ring. Place the spring over the pressure plate and then install the cover with the outlet port in the correct position. Tighten the cover screws to the torque shown in Figure 8. Rotate the shaft by hand to insure that there is no internal binding. Install the shaft key.

If a foot mounting is used, assemble the pump to its foot mounting. If a gasket is used, be certain it is flat to avoid misalignment of the shaft.

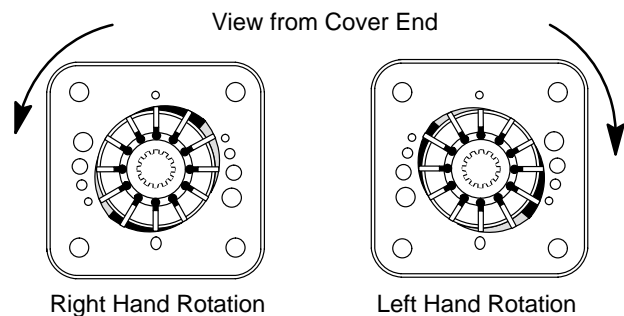

Figure 10.

## Section VII – Testing

If a test stand is available, the pump should be tested at the recommended speeds and pressures shown in the application catalog. See Table 1.



---

Eaton  
14615 Lone Oak Road  
Eden Prairie, MN 55344  
USA  
Tel: 952 937-9800  
Fax: 952 974-7722  
[www.hydraulics.eaton.com](http://www.hydraulics.eaton.com)

Eaton  
20 Rosamond Road  
Footscray  
Victoria 3011  
Australia  
Tel: (61) 3 9319 8222  
Fax: (61) 3 9318 5714

Eaton  
46 New Lane, Havant  
Hampshire PO9 2NB  
England  
Tel: (44) 23 92 486 451  
Fax: (44) 23 92 487 110



**Vickers**